

REQUEST FOR QUOTATION WC2215

June 16, 2022

WASHINGTON COUNTY COMMUNITY COLLEGE
ONE COLLEGE DRIVE, CALAIS, ME
PHONE: (207) 454-1023, FAX (207)454-1026

PROPOSAL

Washington County Community College is requesting bids to build an outdoor classroom behind the residence hall on the WCCC Campus (see site map). The classroom will need the following components built (please provide itemized quote for each bullet item). Due to budget constraints, the college reserves the right to refuse any and all proposals. In addition, the college reserves the right to reject any or all bids and is not necessarily bound to accept the lowest bid if that bid is contrary to the best interest of WCCC.

GENERAL INFORMATION/SUBMISSION REQUIREMENTS

- A. Bid Opening/Identification of Bid Envelope:** A signed original of the bid must be received at Washington County Community College, 1 College Drive, Calais, ME 04619, in a sealed envelope by 1:00 p.m. June 29, 2022. The signed bid should be returned in a sealed envelope or package and clearly identified as follows. **Alternatively, quotes may be emailed to amacdonald@wccc.me.edu by 12:00 p.m. June 29, 2022, 1:00 p.m.**
Enclosed: Quotation #WC2215 **Attention:** Ashley Macdonald, Business Manager
- B. Site Visit:** A site visit to is scheduled for Wednesday, June 22 at 1:00 p.m.
- C. Covid-19 Protocols:** All visitors must observe Covid-19 safety protocols and pass the WorkSafe screening app before accessing the college. The direction for this app will be provided upon inquiry. If you do not have a mobile phone that can access the app, screening can be conducted on site upon arrival. Vendors must supply proof of vaccination and booster.
- D. Bid Proposal Amount:** The bid proposal amount shall be the net price per unit, including shipping and handling F.O.B. Destination, Washington County Community College, Calais, Maine. Vendor should indicate the length of time RFQ is valid. Note that WCCC is exempt from the payment of Federal Excise Taxes on articles not for resale and for the Federal Transportation Tax on all shipments. The Contractor and all subcontractors shall quote and shall be reimbursed less these taxes. Upon application, exemption certificates will be furnished when required. The College is exempt from the payment of Maine State Sales and Uses taxes.
- E. Evaluation:** Award will be made to the low Bidder(s) whose products or solutions conform best to the RFP and College requirements, provided that all other requirements are satisfactorily met. During the evaluation process, WCCC reserves the right where it may serve the College's best interest to request additional information or clarification from proposers, or to allow corrections of errors or omissions.
- F. Obligations:** Vendor is to assure that all contractors meet state, federal, and OSHA guideline and codes, as applicable. As well as the following Bid Notices in Appendix A.
- G. Insurance:** The Contractor is required to provide WCCC a certificate of insurance evidencing coverage of broad comprehensive liability insurance in the minimum amount of Four Hundred Thousand Dollars (\$400,000). Contractor must also provide evidence of workers' compensation insurance for all workers. Proof of all required insurance coverage must be submitted with the proposal response.
- H. Variations/Alternative Specifications:** Specifications given are used to indicate the quality and characteristics of products that will be satisfactory. Bids offering equal or alternative products will be considered for award if such items are clearly identified in the bid and are determined by WCCC to be of equal value in all material respects to the item specified. Unless the vendor clearly indicates in the bid that they are offering an "equal" or "alternative" product, the bid shall be considered as offering the items **as specified**.

REQUEST FOR QUOTATION WC2215

June 16, 2022

WASHINGTON COUNTY COMMUNITY COLLEGE
ONE COLLEGE DRIVE, CALAIS, ME
PHONE: (207) 454-1023, FAX (207)454-1026

PROJECT DESCRIPTION

The classroom will need the following components built. Please provide an itemized quote for each bullet item.

- Foot trail \$ _____
 - clear trees, branches, and roots for a foot trail measuring approximately 200' long and 4' wide.
 - Install wood chips 4" deep along the trail.
 - Install drainage and gravel over approximately 10' swale.

- 50' diameter classroom area \$ _____
 - remove 7 trees (approx. 8-10" diameter) and their roots
 - remove sod and grade
 - install barrier mat
 - place wood chips 4" deep
 - build and install 16 benches from half-logs (see drawings)
 - prepare fire pit area at center of classroom
 - remove soil to 12" deep in 6' diameter circle at the center of classroom
 - fill with 1" stone to grade

- Tent platform area (see drawings for dimensions and specs) \$ _____
 - Remove brush and trim overhead branches
 - Remove sod and grade
 - Install barrier mat
 - Place wood chips to 4" depth
 - Build and install 4 10'X10' tent platforms (see drawings for dimensions and specs)

- Benches (see drawings for dimensions and specs) \$ _____
 - Build from hemlock or cedar logs
 - Sand seating surface smooth and remove any chance of splinters
 - Notch seat top and base logs
 - Spike seat top to support logs using galvanized spikes

- Build and install 4 picnic tables (see drawings for dimensions and specs) \$ _____
 - Use pressure-treated lumber for legs to prevent rot from ground contact
 - Use hemlock or cedar for tabletops and benches

REQUEST FOR QUOTATION WC2215

June 16, 2022

WASHINGTON COUNTY COMMUNITY COLLEGE
ONE COLLEGE DRIVE, CALAIS, ME
PHONE: (207) 454-1023, FAX (207)454-1026

BID SUBMISSION SHEET

Bid sheet submitted by: _____

Company Name: _____

Contact Name: _____

Phone Number: _____

Email: _____

Pricing Good for _____ days or to date _____

Thank you for your assistance.

**WCCC Outdoor Classroom
Site Map**

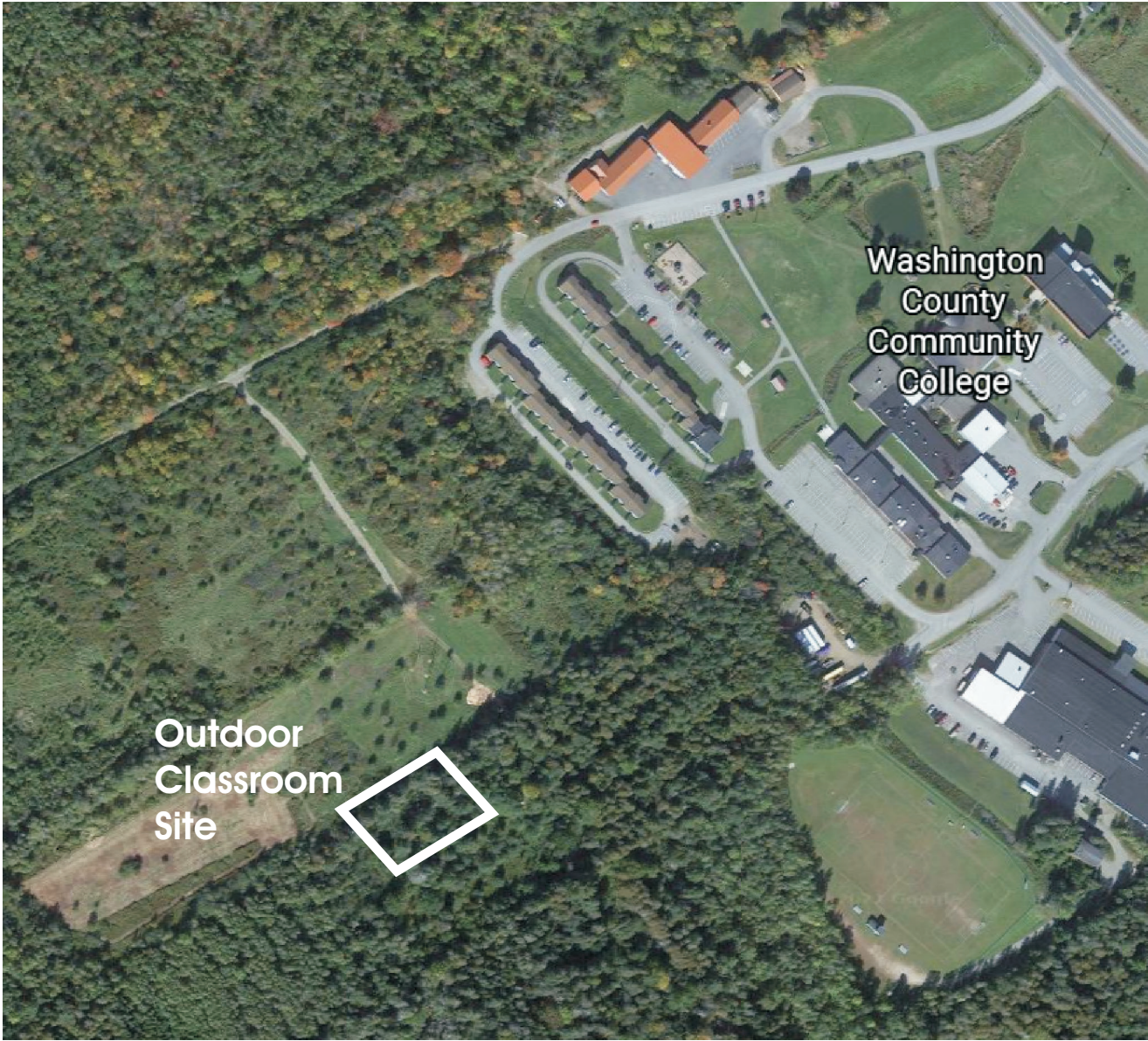

WCCC Outdoor Classroom - Teaching Podium Design Concept



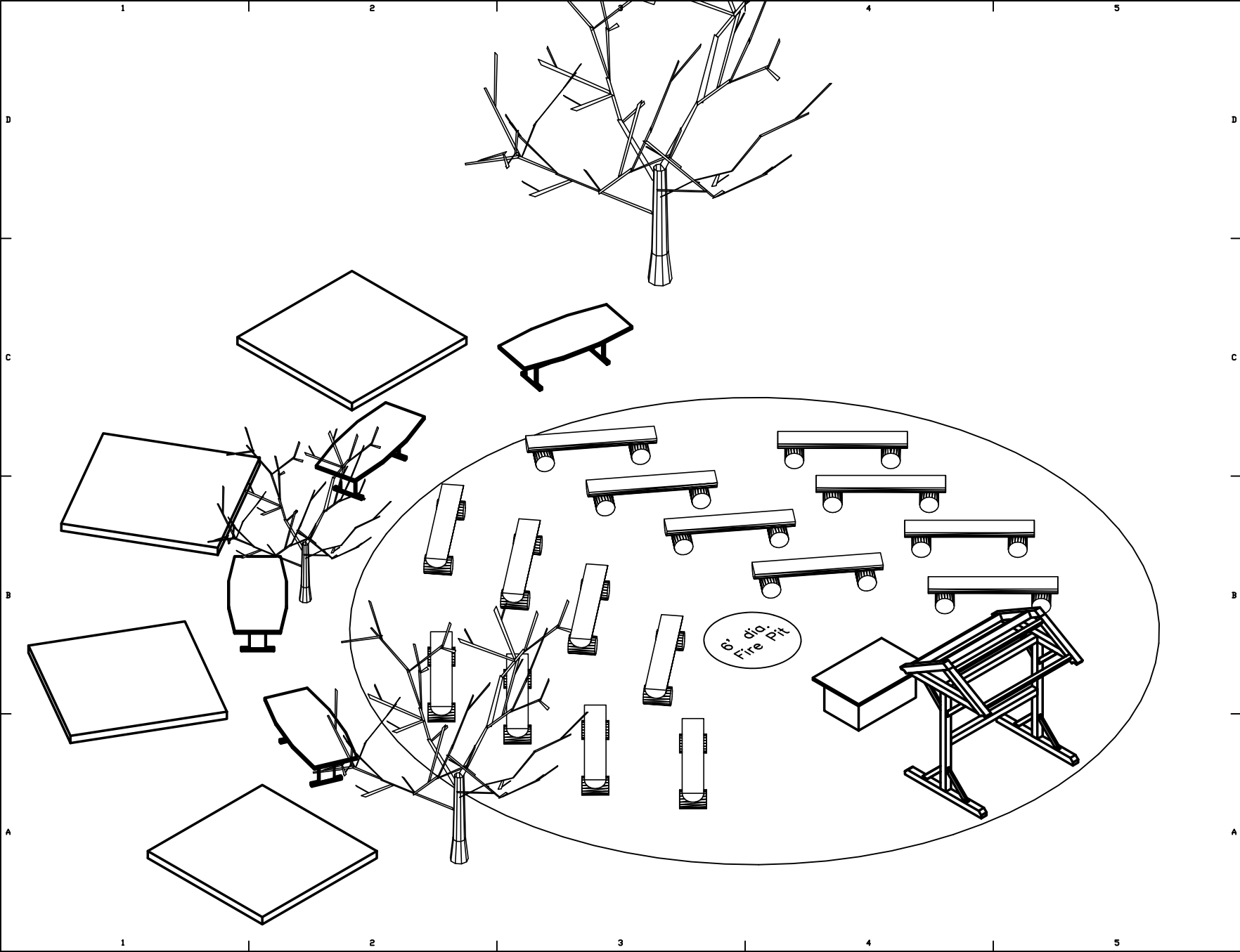

WCCC Outdoor Classroom

SITE PLAN - ORTHO VIEW

PROJECT NUMBER:	000000
ISSUED:	4/28/2021
DRAWN BY:	Scott Fraser
CHECKED BY:	---
FILENAME:	.DWG

A0.1

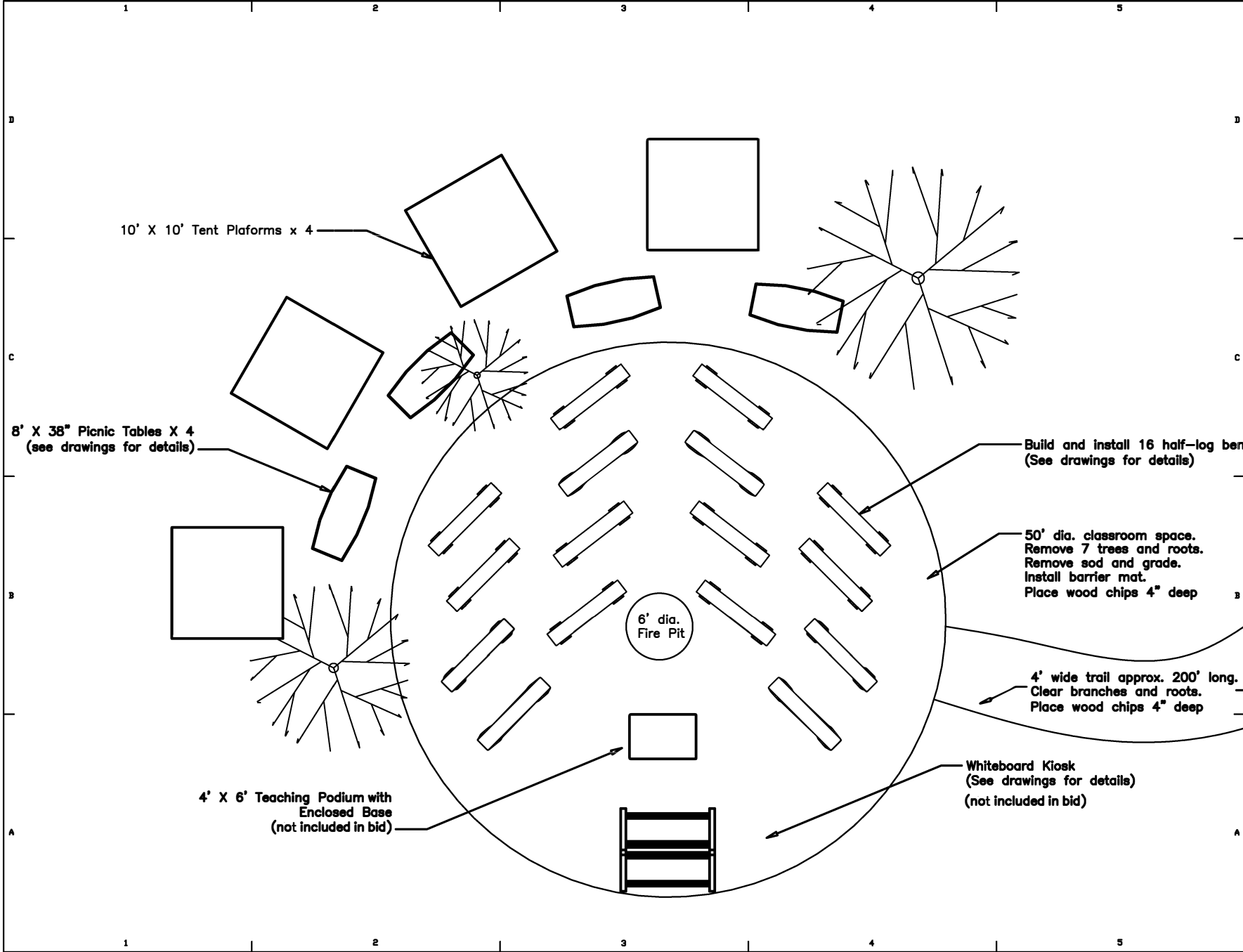

Build and install 16 half-log benches
(See drawings for details)

50' dia. classroom space.
Remove 7 trees and roots.
Remove sod and grade.
Install barrier mat.
Place wood chips 4" deep

4' wide trail approx. 200' long.
Clear branches and roots.
Place wood chips 4" deep

Whiteboard Kiosk
(See drawings for details)
(not included in bid)

10' X 10' Tent Platforms x 4

8' X 38" Picnic Tables X 4
(see drawings for details)

4' X 6' Teaching Podium with
Enclosed Base
(not included in bid)

6' dia.
Fire Pit

WCCC Outdoor Classroom

SITE PLAN

PROJECT NUMBER:	0000000
ISSUED:	4/28/2021
DRAWN BY:	Scott Fraser
CHECKED BY:	
FILENAME:	.DWG

A0.0

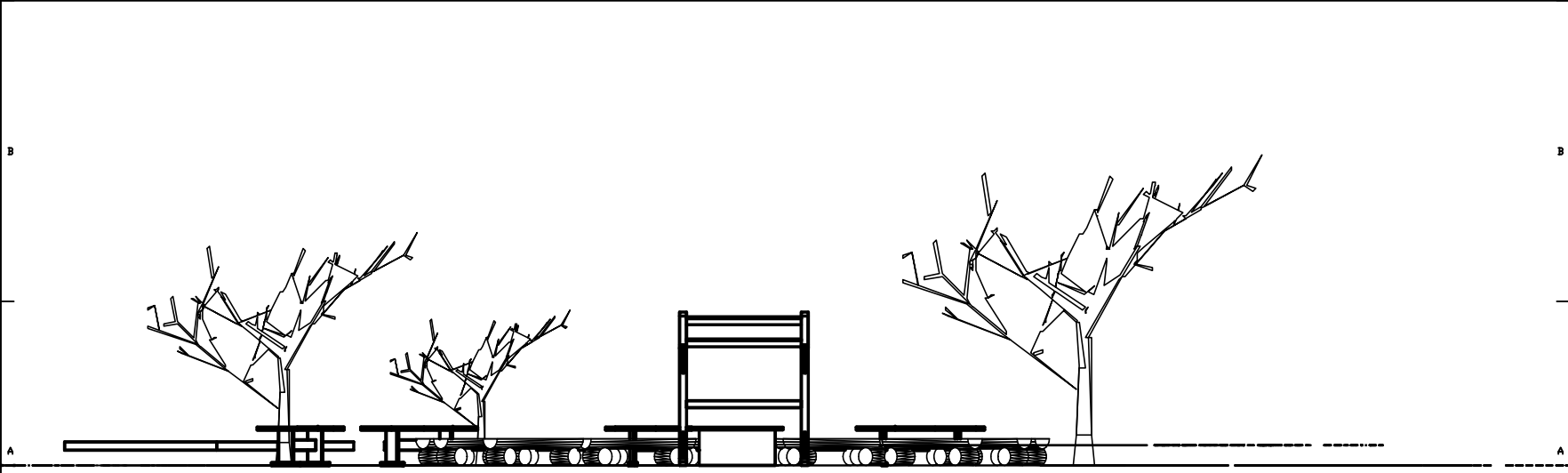
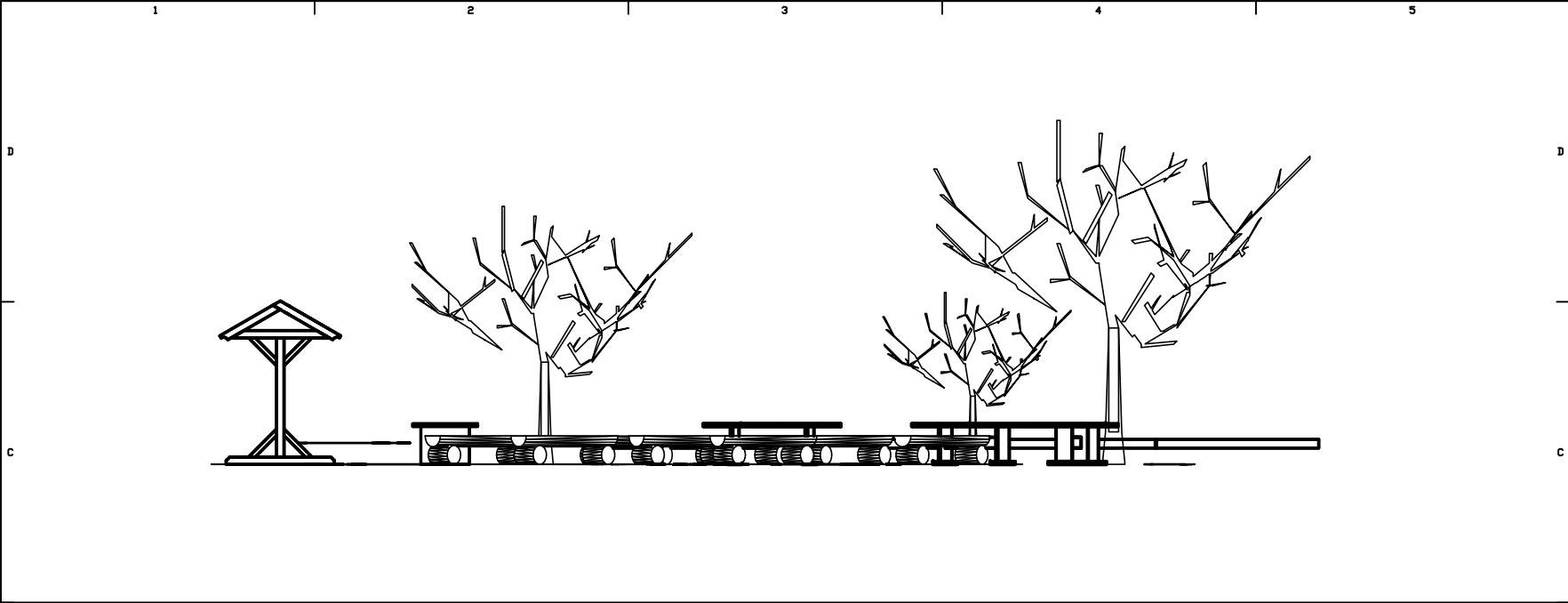

WCCC Outdoor Classroom

ELEVATIONS

PROJECT NUMBER: 0000000
ISSUED: 4/28/2021
DRAWN BY: Scott Fraser
CHECKED BY: ---
FILENAME: .DWG

A2.0

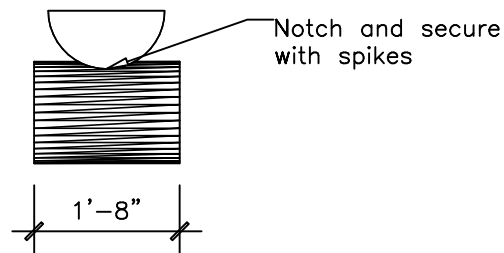
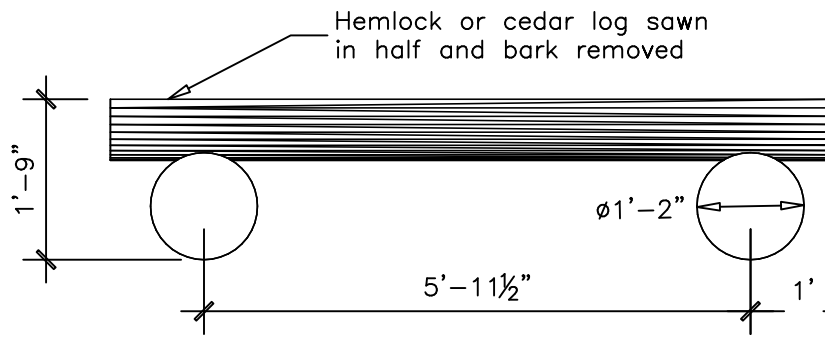
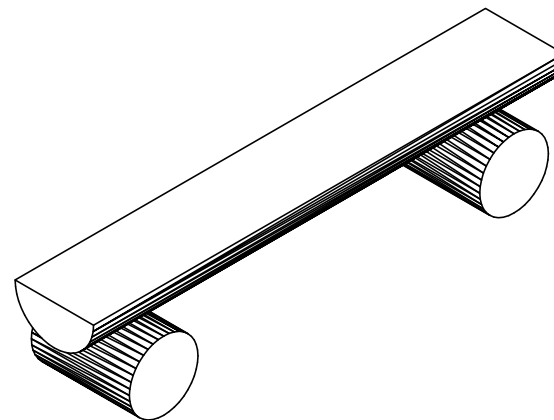
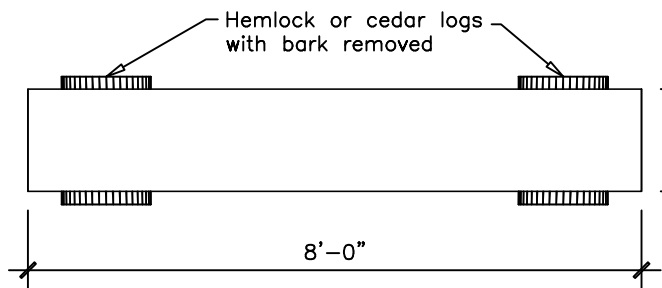

WCCC Outdoor Classroom
-
-
BENCH DETAILS

PROJECT NUMBER: 0000000
ISSUED: 4/28/2021
DRAWN BY: Scott Fraser
CHECKED BY: ---
FILENAME: .DWG

autodesk
Architectural
Desktop

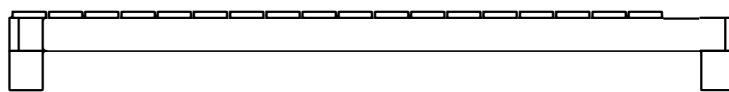
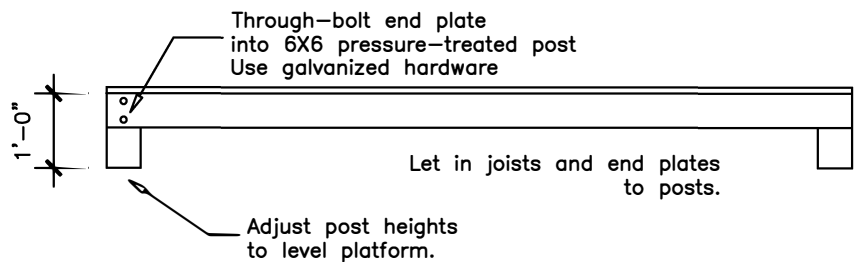
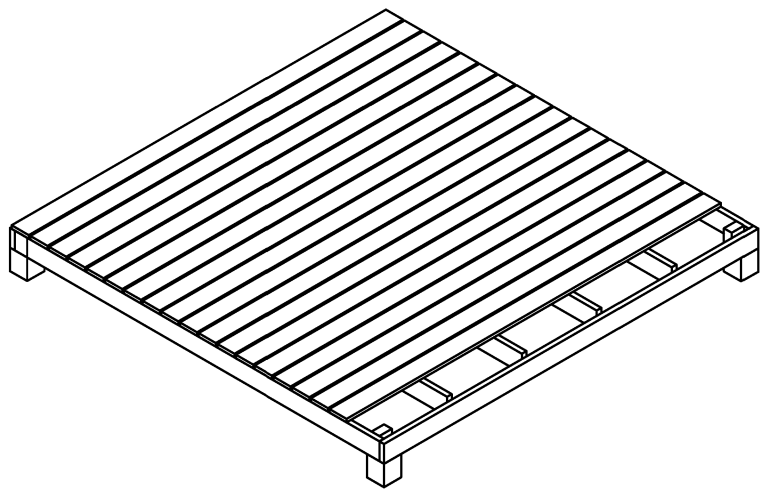
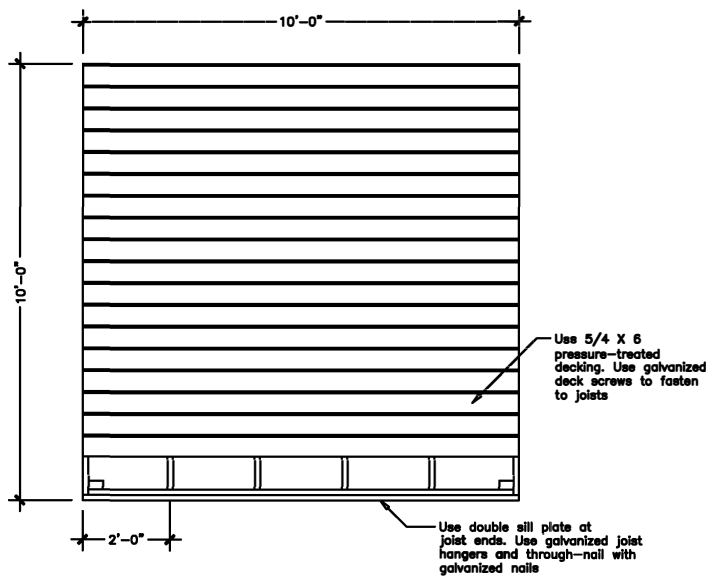

WCCC Outdoor Classroom
-
-
TENT PLATFORM DETAILS

PROJECT NUMBER:	0000000
ISSUED:	4/28/2021
DRAWN BY:	Scott Fraser
CHECKED BY:	---
FILENAME:	.DWG

A5.0

WCCC Outdoor Classroom - Picnic Table Design

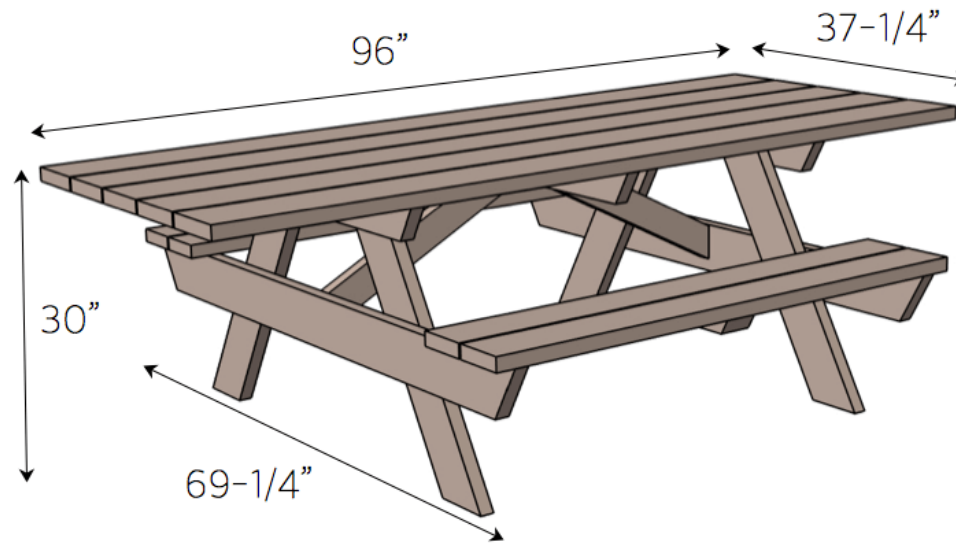

APPENDIX A
MCCS MASTER RIDER TO
VENDOR FORM AGREEMENTS
STANDARD TERMS AND CONDITIONS APPLICABLE TO ALL MCCS CONTRACTS

Notwithstanding any term, condition, provision or section of any contract, agreement, license, schedule, specification, addendum, rider, exhibit or other document or source purporting to govern the transaction (collectively "contract") between ___(insert vendor name)_____, for itself and any subsidiaries or affiliates (collectively "Vendor"), and ___(insert college name)_____ Community College for itself and the Maine Community College System (collectively "MCCS"), Vendor recognizes the governmental status of MCCS and agrees with MCCS to the following priority terms and conditions:

1. MCCS is not obligated to:
 - a. Provide confidentiality in any manner inconsistent with the Maine Freedom of Access Act (FOAA);
 - b. Waive any intellectual property rights; any state or federal statutory or constitutional immunity; or any limitation of liability;
 - c. Provide any defense, hold harmless or indemnity to Vendor; or pay attorney's fees, legal or collection costs, or liquidated damages of any kind;
 - d. Use the Vendor exclusively;
 - e. Procure a type or amount of insurance beyond that which MCCS already maintains; waive any right of subrogation; or add any entity as an additional insured to MCCS policies of insurance;
 - f. Honor any automatic term renewal other than on a month-to-month basis;
 - g. Limit MCCS' recovery of lawful damages incurred as a result of Vendor's breach of the contract;
 - h. Limit the time period under which claims can be made or actions brought arising from the contract;
 - i. Provide precedence to Vendor's terms over MCCS' standard terms and conditions, including addenda; or
 - j. Honor any unilateral modification to the contract by Vendor.
2. The laws of the State of Maine shall govern the performance and interpretation of the contract, without regard to conflicts of laws, and the State of Maine shall be the forum for the resolution of any disputes thereon.
3. Vendor will identify at the time of contract signature which, if any, portion of Vendor's submitted materials are entitled to "trade secret" exemption from disclosure under FOAA. Failure to so identify will authorize MCCS to conclude that no portions are so exempt. Vendor will defend, indemnify and hold harmless MCCS in any and all legal actions that seek to compel MCCS to disclose under FOAA some or all of Vendor's submitted materials and/or contract, if any, executed between MCCS and Vendor.
4. Vendor and MCCS do not intend to or grant any rights to any third party. Vendor shall not change unilaterally any term or condition of the contract. Any early termination by MCCS shall not result in an MCCS obligation to pay more than a pro-rated amount.